

ST Pretest 2.2

1. When clothes tumble-dry they become statically charged?
 - a. Why?
 - b. If the clothes are *not* allowed to dry completely, will they still be charged?
2. In the diagram below,
 - a. explain why the leaves of the electroscope are moving apart.
 - b. explain how the leaves both became negative, and why the metal sphere is positive.
 - c. explain what would happen if the rod actually touched or was placed extremely close to the sphere.

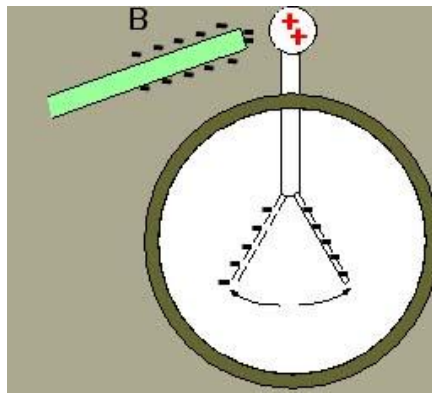

3. For each set, choose the one which offers the *more* resistance
 - a. a wire 40 cm in length and 3 cm wide ___
a wire 40 cm in length and 8 cm wide ___
 - b. a 20 cm wire(length) made of Cu ___
a 30 cm wire made of Cu ___
 - c. a circuit operating at -3°C ___
one operating at 2°C ___

4.

The diagram on the right shows the main parts of an incandescent light bulb.

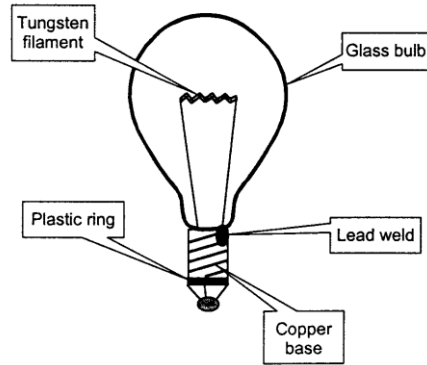

Which of the above substances used to make this light bulb are *insulators*?

5. Two spheres are in contact with one another. The first sphere has twice the charge of the smaller sphere. The larger sphere has an area = 9 cm^2 , and it loses 2 units of charge to the smaller sphere, which in spite of its size, is less crowded because it has so little charge.

How many units of charge did the larger sphere begin with if the smaller sphere's area = 6.75 cm^2 ?

6. Define grounding.
7. What is the conductance of a wire if its resistance is 30Ω ?
8. Which appliance has the greatest electrical resistance?

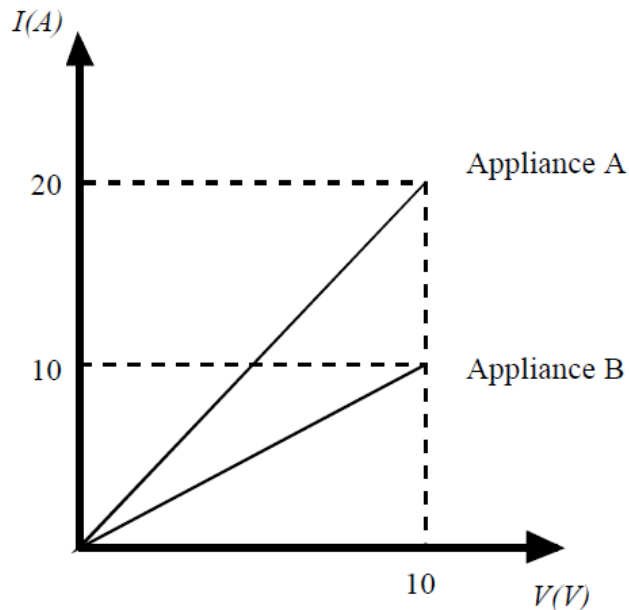

9.

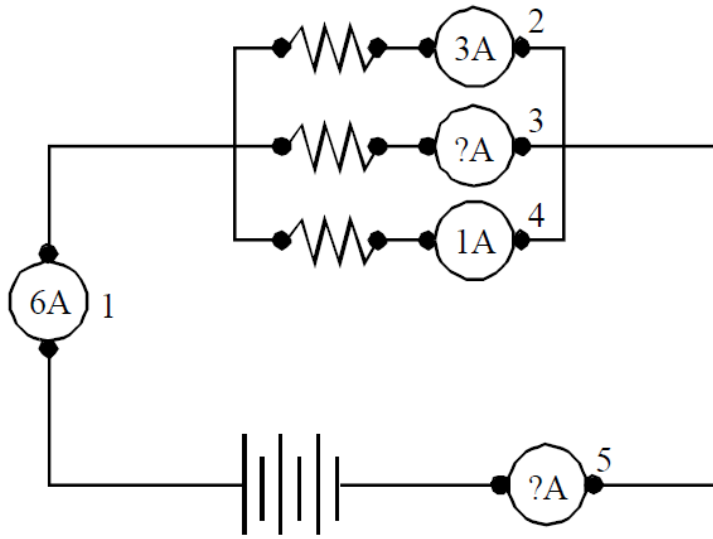

What are the readings of ammeter 3 and ammeter 5?

b) If the total resistance of the circuit is 0.100Ω , find the voltage of the circuit.

10.

How many switches need to be closed to light up one bulb?

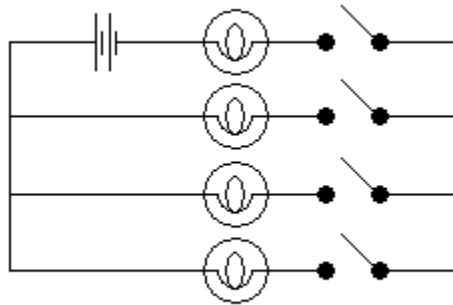

A) 1

B) 2

C) 3

D) 4

b) What kind of circuit will be created by closing that number of switches?

1. When clothes tumble-dry they become statically charged?

a. Why?

b.

As they tumble, they rub against the metal, which transfers electrons to the bed sheets.

b. If the clothes are *not* allowed to dry completely, will they still be charged?

No. Water is great at removing static.

2. In the diagram below,

a. explain why the leaves of the electroscope are moving apart.

Like charges repel. Both pieces are (-)

b. explain how the leaves both became negative, and why the metal sphere is positive.

The negative charge from the rod repelled the electrons from the sphere into the pieces at the bottom.

c. explain what would happen if the rod actually touched or was placed extremely close to the sphere. **The entire electroscope (knob and leaves) would become negative.**

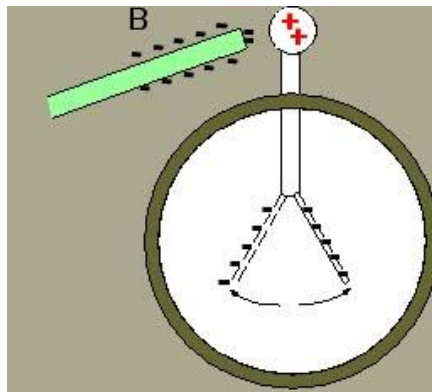

3. For each set, choose the one which offers the *more* resistance

a. a wire 40 cm in length and 3 cm wide X
a wire 40 cm in length and 8 cm wide

b. a 20 cm wire made of Cu
a 30 cm wire made of Cu X

c. a circuit operating at -3°C
one operating at 2°C X

4.

The diagram on the right shows the main parts of an incandescent light bulb.

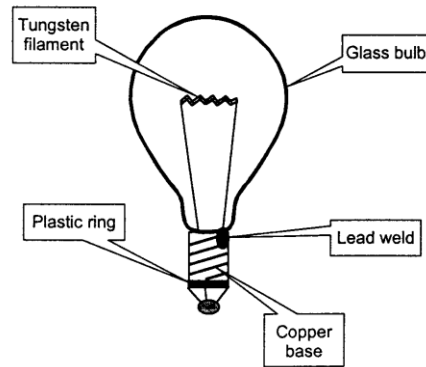

Which of the above substances used to make this light bulb are *insulators*?

Plastic, glass

5. Two spheres are in contact with one another. The first sphere has twice the charge of the smaller sphere. The larger sphere has an area = 9 cm^2 , and it loses 2 units of charge to the smaller sphere, which in spite of its size, is less crowded because it has so little charge.

How many units of charge did the larger sphere begin with if the smaller sphere's area = 6.75 cm^2 ?

$$\frac{2x - 2}{9} = \frac{x + 2}{6.75}$$

$$6.75(2x - 2) = 9(x + 2)$$

$$x = 7$$

$$2x = 14 \text{ units of charge}$$

6. Define grounding.

Grounding is the process by which excess charge is removed from an object.

7. What is the conductance of a wire if its resistance is 30Ω ?

$$\mathbf{G = 1/R = 1/30 = 0.033 \text{ S}}$$

8. Which appliance has the greater electrical resistance? **B has the lowest conductivity) lowest slope (I/V) and therefore the higher resistance.**

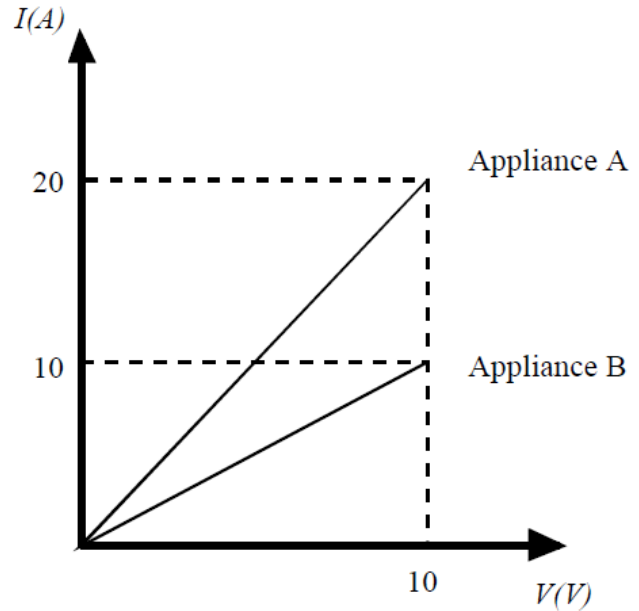

9.

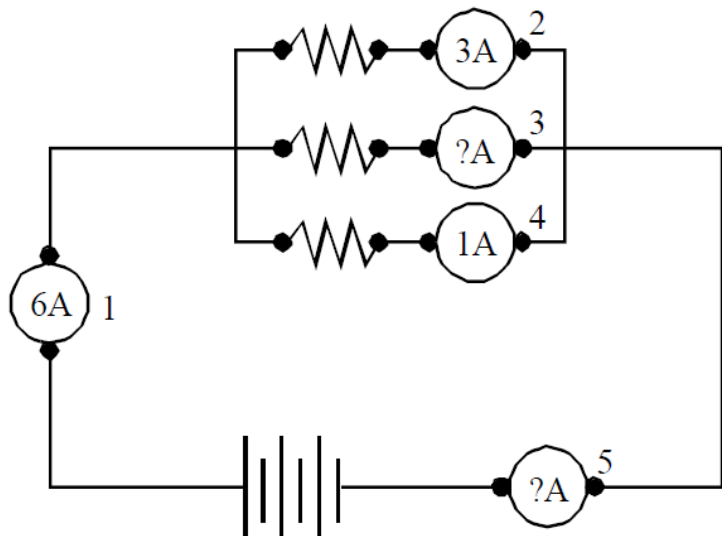

What are the readings of ammeter 3 and ammeter 5?

b) If the total resistance of the circuit is 0.100Ω , find the voltage of the circuit.

a) $A_3 = 6 - (3 + 1) = 2 \text{ A}$

$A_5 = A_{\text{total}} = 6 \text{ A}$

b) $V = IR = 6(0.10) = 0.6 \text{ V.}$

How many switches need to be closed to light up one bulb?

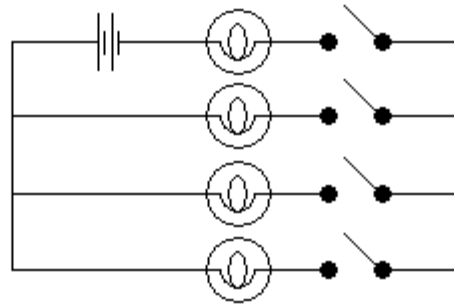

10.

A) 1

B) 2

C) 3

D) 4

2

b) What kind of circuit will be created by closing that number of switches?

Series.